

On the Copenhagen Interpretation and Its Alternative Theories

Haiwen Zhang

Shanghai Pinghe School, Shanghai, China, 200023

caroline2006@163.com

Abstract. Quantum mechanics has become the rising trend in modern physics and has completely changed people's views of physics. This essay delves into the once-existing problems underlying quantum mechanics such as the conflict between substantiality and completeness in quantum mechanics and the relationship between causality and observation and analyzes the solutions to the controversies. The Copenhagen Interpretation is widely considered the most orthodox explanation of quantum mechanics; therefore, this paper focuses on the Copenhagen Interpretation and examines how it delicately manages to explain quantum mechanics. It also examines its alternative theories, such as Einstein's local hidden variable theory, and disproves them with Bell's inequality and other reasonings. The essay aims to clarify and systematize the historical development of quantum mechanics, showing the current progress of quantum mechanics.

Keywords: Copenhagen interpretation, Substantiality and Completeness, Causality and Observation, Bell's inequality, Delayed-choice experiment, Quantum mechanics.

1. Introduction

Before the 1900s, the physics world was dominated by classical mechanics led by Isaac Newton and James Maxwell. However, soon people realized that classical mechanics could not be enough because there was too much that could not be explained. For example, electrons do not radiate energy and fall into the nucleus, as they should have according to Maxwell's equations [1].

In the 1900s, the era of quantum mechanics ushered in a whole new perspective of physics by Max Planck. It arose from the unsolved questions in classical mechanics. Quantum mechanics describes and predicts physical properties at an atomic or subatomic scale [2]. In the mid-1920s, quantum mechanics flourished in the presence of a group of scientists, such as Niels Bohr, Erwin Schrödinger, Werner Heisenberg, Elbert Einstein, etc. It is through the debates of these eminent scientists that quantum mechanics starts to shine and becomes one of the most successful and proven theories in all science.

However, unresolved controversies in quantum mechanics remain. Physicists use quantum mechanics equations to predict subatomic phenomena, but the underlying mechanism remains unknown. In fact, there is no single interpretation of quantum mechanics that has gained consensus agreement from scientists. Nonetheless, this does not stop scientists from speculating the possible mechanism. The Copenhagen Interpretation, the most orthodox explanation of quantum mechanics, was devised in Copenhagen, Denmark by two renowned physicists Niels Bohr and Werner Heisenberg

[3]. Alternative theories also emerge, but none has quite the evidence and consensus from fellow scientists as the Copenhagen Interpretation does.

Two major obstacles in quantum mechanics are the conflict between substantiality and completeness in quantum mechanics and the issue concerning causality and observation. This paper is going to examine how the Copenhagen Interpretation explains these conflicts.

2. Conflicts between substantiality and completeness in quantum mechanics

2.1. Introduction to the conflicts between substantiality and completeness

The famous Schrödinger equation describes the particle's wave function, which states the following:

$$i\hbar \frac{\partial}{\partial t} \Psi(x, t) = \left[-\frac{\hbar^2}{2m} \frac{\partial^2}{\partial x^2} + V(x, t) \right] \Psi(x, t) \quad (1)$$

Conceptually, the Schrödinger equation is the quantum counterpart of Newton's second law in classical mechanics. Unlike classical mechanics, the wave equation is spread out in space instead of localized at a point [4]. To represent the state of a particle, Born's statistical interpretation of the wave function provides the explanation. The probability of finding the particle at time t between a and b states the following [1]: $\int_a^b |\Psi(x, t)|^2 dx$

The Born rule introduces indeterminacy to quantum mechanics, which means that quantum mechanics cannot yield a specific result of a simple experiment. Physicists and philosophers were extremely bothered by the thought that people may live in a fundamentally indeterministic world.

Yet the larger conflict lies in how this probability is distributed in the quantum realm. The famous Heisenberg's uncertainty principle states the following: $\sigma_x \sigma_p \geq \frac{\hbar}{2}$

In this principle, σ_x represents the uncertainty in the position, and σ_p represents the uncertainty in the momentum. The two values are in conjugate space; when the position becomes more precise, the momentum becomes more uncertain. And vice versa.

Scientists have come up with many explanations regarding the conflict, and the most famous of them all are Einstein's local hidden variable theory and the Copenhagen Interpretation.

2.2. Possible theories

2.2.1. *Einstein's local hidden variable theory and the EPR paradox.* Albert Einstein was extremely bothered by the concept that our universe might be fundamentally non-deterministic. As his famous saying goes, "God does not play dice". Therefore, Albert Einstein, Boris Podolsky, and Nathan Rosen, came up with the EPR paradox.

Suppose that the quantum realm is complete. The question is: can it be substantial as well? A common rejection of the conflict between substantiality and completeness in the quantum realm is that the position and the momentum can be both substantial, although not simultaneously. When not measured simultaneously, the position and momentum can both be known at separate times.

The EPR paradox addresses this rejection. Suppose there are two entangled systems. When measuring the position of the particle in System A, the wave function of the position space collapses with the measurement. The wave function of the position space for Particle B also collapses because the two systems are entangled. The measurement of System A causes the position of System B to be substantial, and the momentum of System B is immeasurable. This means that the determinacy of System B depends on System A [5]. However, Einstein cannot accept this unnatural situation. He believes that completeness should be abandoned, and substantiality should remain, suggesting that there is no way for both position and momentum to be substantial [6].

Einstein's local hidden variable theory proposed states that there is a local hidden variable inside Particles A and B, so their states are predetermined before measurement. There is no indeterminacy between System A and B, so the conflict is explained [6].

2.2.2. *The Copenhagen Interpretation.* The most orthodox interpretation of quantum mechanics is the Copenhagen Interpretation, proposed by Niels Bohr and Werner Heisenberg.

Before measurement, all particles exist in a superposition state, which means that the physical quantities, such as the angular momentum, position, and spin, are unknown and unknowable until measurement. The particles are in a superposition of multiple states; a particle can be here and there at the same time.

After measurement, people cannot observe a particle in its superposition, but can only observe it in one state. As stated in the previous section, the wave function is used to describe the particle's state and calculate the probability of finding a particle at a certain point. According to Heisenberg's uncertainty principle, the momentum and the position of the particle are in conjugate space. Upon measurement, the probability lies entirely on one eigenstate, which is 100%, and the probability of the other is undetermined, which is 0%. For example, when the position is measured, the momentum of the particle becomes more uncertain, and vice versa. When measured, the wave function collapses and can no longer describe the quantum system. Therefore, measurement disrupts the quantum system [7].

The difference between the Copenhagen Interpretation and Einstein's local hidden variable theory is that the former denies the existence of a hidden variable and claims that the quantum system is substantial, while the latter acknowledges the completeness of the quantum system.

2.3. Evaluation: Bell's inequality

For decades, scholars debated over which is the correct theory, the Copenhagen Interpretation or the EPR theory. Both theories seem to be reasonable until John Stuart Bell has come up with a simple inequality to resolve the conflict.

Consider a pair of spin particles moving in opposite directions. The spins $\vec{\sigma}_1$ and $\vec{\sigma}_2$ can be measured. When measured, if the component $\vec{\sigma}_1 \cdot \vec{a}$ yields the value of +1, then the measurement of the component $\vec{\sigma}_2 \cdot \vec{a}$ must yield the value of -1, and vice versa. It is hypothesized that if the two measurements are taken at places far from each other, then the orientation of one magnet does not influence the result obtained with the other.

Now let's consider the case under the EPR theory and suppose the hidden variable is represented as λ , which defines the physical state of e- and e+. The hidden variable of the measurement of Particle A is defined as λ_2 . The measurement of A depends on the spin direction \vec{a} , the physical state of Particle A (defined by λ), and the local hidden variable λ_2 . Therefore,

$$A = A(\vec{a}, \lambda, \lambda_2) \quad (2)$$

Similarly, if the spin of Particle B is \vec{b} , and the hidden variable of the measure of Particle B is λ_3 , then

$$B = B(\vec{b}, \lambda, \lambda_3) \quad (3)$$

This study then defines $\lambda = (\lambda_1, \lambda_2, \lambda_3)$. Because of the conservation of angular momentum, $A(\vec{a}, \lambda) = -B(\vec{b}, \lambda)$. Define $\rho(\lambda)$ as the hidden variable probability density function. $P(\vec{a}, \vec{b})$ is the average value of $A \cdot B$ when \vec{a}, \vec{b} is fixed. Since $A = -B$,

$$\begin{aligned} P(\vec{a}, \vec{b}) &= \int \rho(\lambda) A(\vec{a}, \lambda) B(\vec{b}, \lambda) d\lambda \\ &= -\int \rho(\lambda) A(\vec{a}, \lambda) A(\vec{b}, \lambda) d\lambda \end{aligned} \quad (4)$$

It is also known that $(A(\vec{b}, \lambda))^2 = 1$. Therefore,

$$P(\vec{a}, \vec{b}) - P(\vec{a}, \vec{c}) = \int \rho(\lambda) [A(\vec{a}, \lambda) B(\vec{b}, \lambda) - A(\vec{a}, \lambda) B(\vec{c}, \lambda)] d\lambda$$

$$= -\int \rho(\lambda) [(1 - A(\vec{a}, \lambda) A(\vec{c}, \lambda)) A(\vec{a}, \lambda) B(\vec{b}, \lambda)] d\lambda \quad (5)$$

It is already known that $A(\vec{a}, \lambda) B(\vec{b}, \lambda) = \pm 1$ and $A(\vec{b}, \lambda) A(\vec{c}, \lambda) \geq 0$; and the famous Bell's inequality is as follows [8]:

$$|P(\vec{a}, \vec{b}) - P(\vec{a}, \vec{c})| \leq 1 + P(\vec{b}, \vec{c}) \quad (6)$$

However, in Einstein's local hidden variable theory, $P(\vec{a}, \vec{b}) = \vec{a} \cdot \vec{b}$. Under this circumstance, the Bell inequality is written as $\sqrt{2} \leq 1$, which means that the Bell inequality does not apply under the EPR theory.

3. Causality and observation in quantum mechanics

3.1. Introduction to the issue concerning causality and observation

The key concept of quantum mechanics lies in wave-particle duality. The conflict has long started since the double-slit experiment. In the double-slit experiment, an interference pattern appears when not observed. However, the interference pattern disappears when observed, and the emitted electron behaves as a particle. The issue was again highlighted in Wheeler's delayed-choice experiment. The experimental setup of the experiment reveals whether the particle or wave nature of a quantum system is determined before or after the system has entered the apparatus.

Wheeler's delayed-choice experiment is designed as the following: the photon emitter is at the left-top of the drawing and releases photons in an unknown state of either wave or particle. A photon has entered the quantum system when it enters a Mach-Zehnder interferometer (at BS1). At the right-top and left-bottom of the drawing, there are two reflectors used to reflect the photons at an angle of 90° . At BS2, there is a beam splitter. The experimenter can choose whether to remove the beam splitter at BS2. At the end of Paths d and e lies two detectors to detect the state of the photons. Wheeler's delayed-choice experiment shows that if the beam splitter exists at BS2, then interference will be detected by the detectors, which means that the photon behaves as a wave. However, without BS2, the photon behaves as a particle since the detector at the end of Paths d and e randomly detect the photon, which means that the probabilities the particle chooses Paths b or c are the same (both 50%). The experiment is shown as the following in Figure 1:

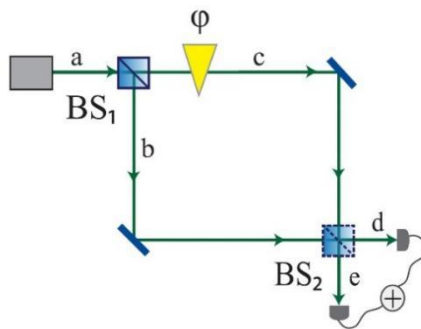

Figure 1. Wheeler's delayed-choice experiment [9].

Wheeler then proposed the question: During which state in the experiment does the photon decide its state as either wave or particle? The central idea of the experiment lies here. Suppose the experiment begins without the beam splitter at BS2. The photon will behave as a particle since it assumes that the second beam splitter does not exist. Common sense would suggest that the photon will continue to act as a particle even when the experimental setting changes. The state of the particle is predetermined and it will go down the path it has chosen when emitted. However, when the beam splitter is popped

up at BS2, the photon changes its state to waves by changing its path because the detector has detected interference. The photon behaves as if the second splitter has already been there the whole time [10].

Note that in this experiment, the cause is the existence of the beam splitter at BS2, and the effect is whether the photon chooses one of the two paths b and c or both paths at the same time, which determines their behaviors as waves or particles. The findings pose a significant philosophical question: Can our choice change the past? The causality seems reversed in the quantum realm. Scholars have come up with several explanations for the conflict.

3.2. Explanations

3.2.1. Wheeler's explanation. Wheeler believes that the findings in the delayed-choice experiment do not raise the conflict of a fundamentally reversed universe of causality. He believes that the findings do not mean the present choice can influence the past. Rather, he thinks that the past has no existence until it is recorded in the present. There is no past until the point when you make the measurement in the present, and thereby the past comes along with the present [11].

3.2.2. The Copenhagen Interpretation. Bohr also has his own explanation for the delayed-choice experiment. Unlike Wheeler's explanation which states that the past does not exist until it is measured in the present, but rather it was not possible to give explanations to the quantum phenomena as in classical physics anymore. According to the Copenhagen Interpretation, it is impossible and meaningless to visualize the quantum process. Making a sharp separation between the properties of the observed system and the observing apparatus would also be impossible. Bohr once wrote:

In any attempt of a pictorial representation of the behaviour of the photon we would, thus, meet with the difficulty: to be obliged to say, on the one hand, the photon always chooses one of the two ways and, on the other hand, that it behaves as if it passed both ways.

The central explanation of the Copenhagen Interpretation is that scientists should just calculate based on the quantum phenomena without asking questions because it is futile to visualize the quantum process [11].

3.2.3. Bohm Interpretation. In Bohm's interpretation, there is a global hidden variable behind the quantum system. In this way, Bohm has avoided the measurement conflict existing in quantum mechanics. The particle is always under the law of classical mechanics unless it is placed in the quantum system where a global hidden variable is controlled. The central idea of Bohmian mechanics is that the system of particles is deterministic and choreographed by the wave function. As in the double-slit experiment, the photon acts under the law of classical mechanics and has a definite trajectory, passing through one of the two slits. The slit through which it passes depends wholly upon its initial position and wave function. There is no uncertainty in quantum mechanics, but rather, the past is already predetermined. In Wheeler's delayed-choice experiment, the photon stays as a particle until it detects the presence of the other beam splitter and changes to a wave [12].

However, the Bohmian Interpretation is refuted because it is inconsistent with general relativity. The Bohmian mechanics cannot describe fast particles close to the speed of light. Still, the Bohmian mechanics failed to give theoretical updates compared to the Copenhagen Interpretation, but rather, it accords with the common knowledge of classical mechanics.

4. Conclusion

This paper has delved deep into the various interpretations of quantum mechanics. The essay begins by introducing the origins of quantum mechanics and its developing history, addressing some of the great scientists that had contributed to its development. This paper focuses on the most orthodox interpretation of quantum mechanics, the Copenhagen Interpretation, and expands on its alternative theories to observe two of the ingrained conflicts in quantum mechanics: The conflict between substantiality and completeness, and the causality and observation in quantum mechanics. After

introducing the conflict at the beginning of every section, the elegant explanation of the Copenhagen Interpretation is presented. Some other explanations are also included; despite their weaknesses compared with the Copenhagen Interpretation, it is still believed that it is worthwhile to explore them in-depth.

However, the Copenhagen Interpretation still has flaws. The Copenhagen Interpretation fails to provide the descriptions of the collapse of wave functions. It does not explain whether the collapse is instantaneous or continuous. It also fails to give a clear definition of causality. As some alternative theories, such as Wheeler's explanation in 3.2.1, have proposed, the cause and effect are an integral whole without a time difference since the past does not exist until current measurements is taken. The causality is counterintuitive in this sense. Therefore, the Copenhagen Interpretation still needs refinement.

References

- [1] De Gosson, Maurice A. Principles of Newtonian and Quantum Mechanics, The: The Need for Planck's Constant [M] H. World Scientific, 2016, pp.3-5.
- [2] Jaeger, Gregg. What in the (quantum) world is macroscopic [J] American Journal of Physics 82.9, 2014, pp.896-905.
- [3] Gbur, Gregory J. Falling Felines and Fundamental Physics [J] Yale University Press, 2019, pp. 264–290.
- [4] Griffiths, David J., and Darrell F. Schroeter. Introduction to quantum mechanics [M] Cambridge university press, 2018, pp.1-3
- [5] Horodecki, Ryszard, et al. Quantum entanglement [J] Reviews of modern physics 81.2, 2009, pp.865.
- [6] Einstein, Albert, Boris Podolsky, and Nathan Rosen. Can quantum-mechanical description of physical reality be considered complete? [J] Physical review 47.10, 1935, pp.777.
- [7] Howard, Don. Who invented the “Copenhagen Interpretation”? A study in mythology [J] Philosophy of Science 71.5, 2004, pp.669-682.
- [8] Bell, John S. On the Einstein Podolsky Rosen paradox [J] Physics Physique Fizika 1.3, 1964, pp.195-200.
- [9] Chaves, Rafael, Gabriela Barreto Lemos, and Jacques Pienaar. Causal modeling the delayed-choice experiment [J] Physical review letters 120.19, 2018, pp.190-401.
- [10] Peruzzo, Alberto, et al. A quantum delayed-choice experiment [J] Science 338.6107, 2012, pp.634-637.
- [11] Hiley, B. J., and R. E. Callaghan. Delayed-choice experiments and the Bohm approach [J] Physica Scripta 74.3, 2006, pp.336.
- [12] Holland, Peter R. The quantum theory of motion: an account of the de Broglie-Bohm causal interpretation of quantum mechanics [M] Cambridge university press, 1995, pp.2-6.