

Modelling and Analysis of Quantum Security Architecture for B5G Fronthaul Network

Yunyang Kuang

Beijing University of Posts and Telecommunications, 10 Xitucheng Road, Haidian District, Beijing

2019213226@bupt.edu.cn

Abstract. To satisfy the urgent requirements of security for fifth generation (5G) fronthaul network, quantum key distribution (QKD) technique is taken into consideration as a promising way. In this paper, we first propose an architecture for quantum security beyond fifth generation (B5G) fronthaul optical network, which merges facilities of QKD into the architecture of existing 5G fronthaul network, enabling quantum signals to be transmitted with classical signals within the same fiber. Secondly, theoretical model analysis of interference with quantum signals caused by four wave mixing noise is performed. Moreover, the theory of secure key rate calculation under noise interference is introduced. Lastly, the QKD performance in the proposed architecture is evaluated, which leads to the conclusion that even when the quantity of B5G fronthaul optical channels for classical signals reaches up to 12, the secure transmission distance of QKD is still beyond 20km, which satisfies the demand of B5G fronthaul optical network.

keywords: Quantum key distribution, B5G optical network, Noise analysis.

1. Introduction

As the new generation of communications, the fifth generation mobile communication technology (5G) is of great advantages for its high speed, ubiquitous network, low power consumption, short time-delay and interconnection of everything, which determines that beyond fifth generation (B5G) technique is destined to play an important role in promoting the information society we are living in [1]. The optical network of B5G is divided into 3 parts: fronthaul, middlehaul, backhaul, among which fronthaul is the part that plays a crucial role by connecting massive amounts of base stations and nodes [2]. However, according to research in [3], there are urgent needs for security protection of B5G fronthaul network.

With the rapid development of quantum computing technology, traditional encryption methods achieved by significantly increasing computational complexity are highly threatened. To meet the requirement of security protection for B5G fronthaul network, quantum key distribution (QKD) using quantum mechanics to guarantee its safety is considered as an excellent option [4]. With the aid of QKD in generating and distributing secure keys, One-Time-Pad which has been proved to be the only known method that has theoretical security could be operated successfully [5].

In order to save the cost of fiber, quantum signals are commonly transmitted together with classical signals in the same fiber. However, this method could lead to some problems of noise interference for quantum signals, such as four-wave mixing (FWM) noise from classical signals. The power of quantum signals are much less than that of classical signals, thus quantum signals can be easily influenced by

noise generated by classical signals when transmitting in the same fiber. There are two multiplexing methods of quantum and classical signals. The first is coarse wavelength division multiplexing (CWDM), which transmits classical signals and quantum signals through different frequency bands, for example, transmitting classical signals through C band, and transmitting quantum signals through O band. By using this method, it is less likely for quantum signals to be interfered by noise of classical signals. However, quantum signal will suffer from a much higher attenuation than classical signals. The other is dense wavelength division multiplexing (DWDM), transmitting both classical signals and quantum signals through the same band, such as C band, but using this method we have to find out a way to deal with noise problems.

The solutions for solving the noise problems of transmitting both classical and quantum signals within the same fiber have been studied by many researchers before [6-9]. Both FWM noise and spontaneous Raman (SpRS) noise were taken into consideration and the joint optimized channel allocation scheme was proposed to reduce the impairments on quantum signals [6]. Influence on wavelength of quantum channel multiplexed with a classical channel caused by spontaneous Raman noise were estimated [7]. Standard telecom fiber was successfully used to transmit the combination of QKD and optical transport network of classical data at certain launch power and data rate [8]. An analytical model of SpRS noise that is capable of well improving secure key rate (SKR) for long distance transmission was formed [9]. The above research is relatively complete for simultaneous transmission of classical signals and quantum signals, but has not been analyzed in combination with specific applications, such as the requirements of B5G scenario.

Aiming to solve noise problems, we are going to propose an optical network architecture of B5G fronthaul based on quantum encryption, then formulates the FWM noise model caused by classical signals and estimation for SKR of QKD. Finally, simulation for SKR of QKD in the proposed architecture together with feasible solutions for practical transmission will be introduced in the end.

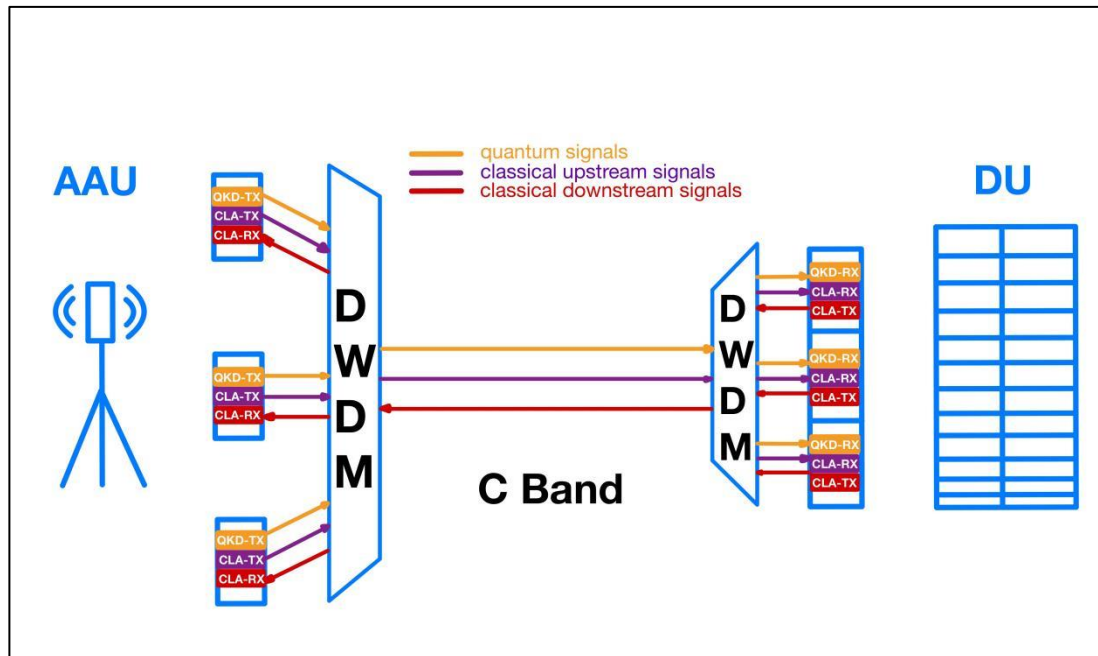

Figure 1. B5G fronthaul optical network architecture of quantum security.
 (CLA: classical signals; QKD: quantum signals; TX: transmitter; RX: receiver)

2. Architecture Design of Quantum Security B5G Fronthaul Optical Network

We proposed a B5G fronthaul network architecture of quantum safety as shown in Fig. 1. There are three main parts in the architecture: active antenna unit (AAU), dense wavelength division multiplexing (DWDM), distribute unit (DU) which are connected by optical fibers. During the process, distributed

AAUs are able to transmit quantum signals (unidirectional to generate and distribute quantum key when upstreaming) and classical upstream signals simultaneously to a same DWDM. The DWDM gathers those signals together and transmits them to a DWDM of DU, where the quantum signals and classical upstream signals will be demultiplexed and transmitted to the corresponding processing unit of DU. Classical downstream signals from DU are transmitted back by the same process to AAUs.

3. Analytical Model of FWM Noise

When two or three beams of light with different frequencies are transmitted within the same fiber, there will be interactions among them which leads to the consequence of generating light with different frequencies that interfere with the quantum channels, and the new light could even have the same frequencies as original ones under certain circumstances which could cause huge impact on the quantum channels. When weak quantum signals are transmitted with classical signals together within the same fiber, there is a higher possibility of interference for quantum signals caused by classical ones, hence we need to do theoretical analysis on the FWM noise.

Assuming that light waves are polarized along the direction x and transmitted along the axial direction z of the fiber. By substituting Fourier integral form of the field intensity and the induced nonlinear polarization into the wave equation then integrating the function along axis z, we will get the intensity of the electric field caused by the new light [10]:

$$E_4(L) = i \frac{2\pi\omega_F}{n_4 c} (DX_{1111}) E_3^* E_1 E_2 \exp(-\frac{1}{2}\alpha L) \left(\frac{1 - \exp[-(\alpha + i\Delta k)L]}{\alpha - i\Delta k} \right) \quad (1)$$

In the equation, E stands for the intensity of electric field, ω is the oscillation frequency of optical signals, k represents the propagation constant and α is the attenuation coefficient of fiber. D is the FWM degeneracy factor, X is the third-order nonlinear susceptibility. L is the length of fiber, and n is the Refractive Index of fiber.

Then we can obtain the power equation [11]:

$$P_4 = \frac{256\pi^4 \omega_4^2}{n_1 n_2 n_3 n_4 c^4} (DX_{1111})^2 \exp(-\alpha L) \frac{P_1 P_2 P_3}{A_{eff}^2} \left| \frac{1 - \exp[-(\alpha + i\Delta k)L]}{\alpha - i\Delta k} \right|^2 \quad (2)$$

where P represents the power of noise signals, and A_{eff} is the effective area of the fiber.

We denote the efficiency of FWM by η , which is the the ratio of phase mismatching power, and $\Delta\beta$ stands for the factor of phase mismatch [12]:

$$\eta = \frac{\alpha^2}{\alpha^2 + \Delta\beta^2} [1 + 4\exp(-\alpha L) \sin^2(\frac{\Delta\beta L}{2}) / (1 - \exp(-\alpha L))^2] \quad (3)$$

Thus according to this equation, the interference of FWM caused by classical signals to quantum signals can be estimated.

4. Calculation Model of SKR for QKD

The noise in quantum channels have been calculated, and the SKR of QKD is analyzed below. Since the single photon detector itself has dark counts noise, we should mainly consider both dark counts noise and FWM noise when calculating SKR. We denote the background noise by Y_0 , so Y_0 can be represented as:

$$Y_0 = 2p_{dark} + p_{FWM} \quad (4)$$

where p_{dark} stands for the detecting probability of dark counts noise, and p_{FWM} stands for the detecting probability of FWM noise.

Then the minimum value of SKR can be calculated by the following inequation:

$$SKR \geq q\{-Q_\mu f(E_\mu) H_2(e_\mu) + Q_1 [1 - H_2(e_1)]\} \quad (5)$$

In the inequation, q is the protocol-related fixed efficiency(for BB84 protocol, $q=1/2$), Q stands for the gain of the signal state, $f(E_\mu)$ means the error correction efficiency of bidirectional error correction algorithm, H represents entropy, and e_μ is quantum bit error rate(QBER) of μ photons.

5. Simulation and Results

To find out the impact of B5G upstream classical signals on performance of QKD, we simulate the influence of FWM noise generated by B5G upstream classical signals to SKR and quantum bit error rate of quantum signals based on the architecture and theoretical analysis mentioned above. In the simulation, frequencies of classical channels are at level of THz, and 3 types of transmission are taken into consideration:

- (1) 4 channels of classical signals (193THz, 193.05THz, 193.1THz, 193.15THz).
- (2) 8 channels of classical signals (193THz, 193.05THz, 193.1THz, 193.15THz, 193.2THz, 193.25THz, 193.3THz, 193.35THz).
- (3) 12 channels of classical signals (193THz, 193.05THz, 193.1THz, 193.15THz, 193.2THz, 193.25THz, 193.3THz, 193.35THz, 193.4THz, 193.45THz, 193.5THz, 193.55THz).

And among these types, the quantum channels are all located at 192.9THz.

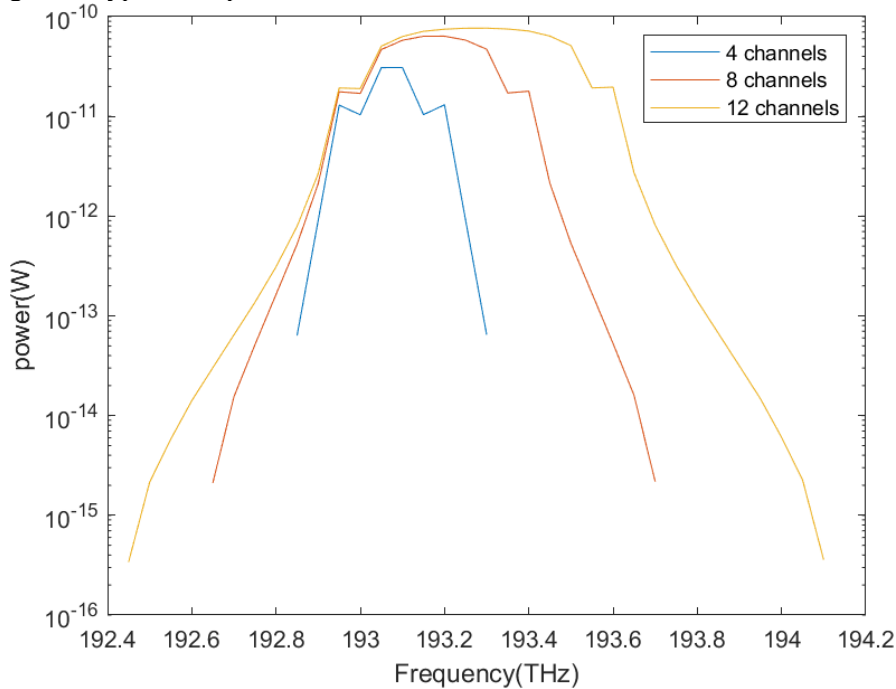

Figure 2. The power of FWM noise in different channels.

In Fig.2, we analyze the FWM noise power in each channel allocation with fixed classical signal power($1e-3W$) and transmission distance(10km) for 3 types classical channel allocation. From Fig.2, it can be observed that the more channels allocated to classical signals, the wider FWM noise can be spread in frequency domain. And noise appears to be stronger and more centralized at nearby frequencies of classical signals. Under certain circumstances, even classical signals themselves can be disturbed by the FWM noise.

In Fig3, we analyze the trend of SKR and quantum bit error rate with fixed classical signal power($1e-5W$) and change of transmission distance from 0km to 100km for 3 types. It shows that when the power of classical signal is given, SKR keeps decreasing while quantum bit error rate keeps increasing with the expansion of transmission distance. And if transmission distance increases above a certain value, SKR will decrease more significantly. For multiple access signals, the more classical signals are transmitted together, with certain classical signal power and transmission distance, the lower SKR and the higher quantum bit error rate occurs, which means the more impact to quantum channel. However,

even when transmitted with 12 channels of classical signals, safety transmission distance could still surpass 20km, which can meet the requirement of B5G fronthaul network.

In Fig.4, we analyze the trend of SKR and quantum bit error rate with fixed signal transmission distance(10km) and change of classical signal power from $1e-7W$ to $4e-5W$ for 3 types(4,8,12 different channels of classical signals transmitted together with quantum signal). It shows that when the transmission distance is given (10km in this simulation), SKR keeps decreasing while quantum bit error rate keeps increasing with the classical signal power. And if classical signal power increases above a certain value ($1e-5W$ in this simulation), SKR will decrease more significantly. Moreover, for multiple access signals, the more classical signals are transmitted together, with certain classical signal power and transmission distance, the lower SKR and the higher quantum bit error rate occurs, which means the more impact to quantum channel.

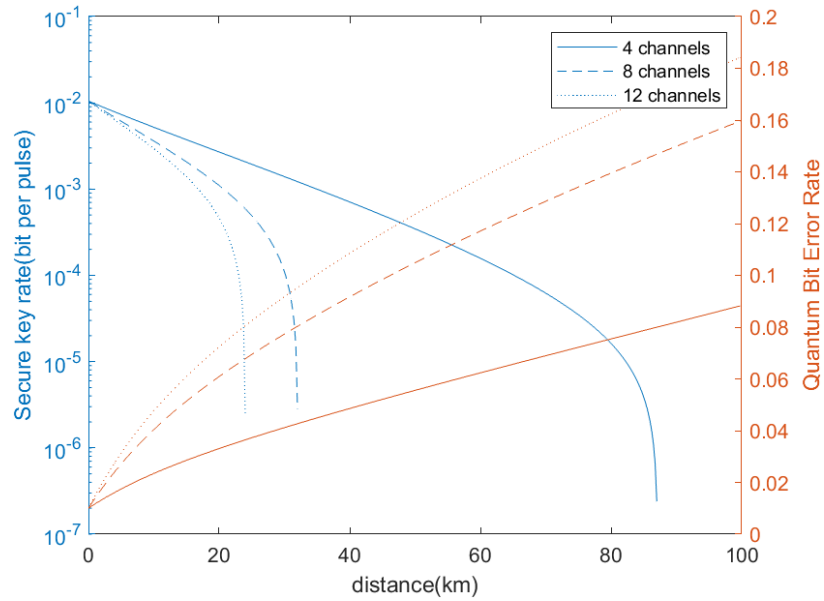

Figure 3. The relationship between QKD performance and transmission distance.

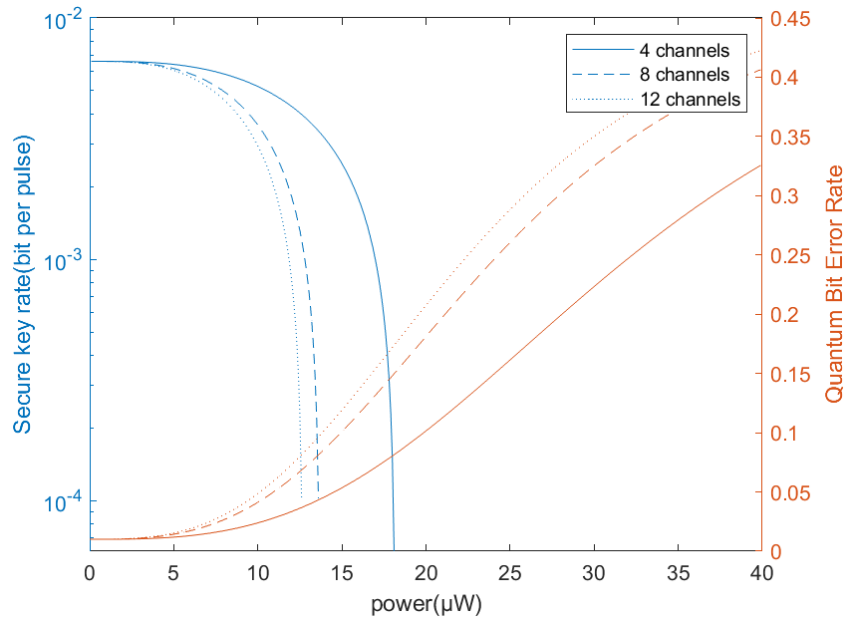

Figure 4. The relationship between QKD performance and power of classical signal.

According to the simulation, to reduce noise interference on quantum security B5G fronthaul network architecture, two ways can be mainly considered. On the one hand, on the premise that the classical signal is successfully received and demodulated, the power of the classical signal can be reduced as much as possible, so as to lower the noise interference to the quantum signal. On the other hand, enlarging the frequency difference of quantum signal and classical signals can also reduce the interference of FWM noise generated by classical signals to quantum signal. Conclusions given by the paper are capable of offering reference to the design of quantum security B5G fronthaul optical network.

6. Conclusions

In this paper, we have proposed an architecture for quantum security 5G fronthaul optical network, and made QKD a promising application in the 5G fronthaul. By combining estimation of interference with quantum signal caused by FWM noise, and theoretical analysis of SKR, we simulate the performance of QKD and quantum bit error rate changed with transmission distance and power of classical signals under the proposed architecture. Therefore, in order to pursue good QKD performance, we can enlarge the frequency spacing of quantum signals and classical signals is capable of reducing interference of FWM noise. Also, on the premise that the classical signal is successfully received and demodulated, lower power of classical signal can also reduce interference of FWM noise.

References

- [1] Wei Chen. "Experimental research on fiber quantum key distribution." a dissertation for doctor's degree, 2008.
- [2] IMT-2020(5G); "White paper on 5G bearer network architecture and Technical plan.", 2018
- [3] Cho, Joo Yeon, Andrew Sergeev, and Jim Zou. "Securing ethernet-based optical fronthaul for 5g network." Proceedings of the 14th International Conference on Availability, Reliability and Security. 2019.
- [4] Xiaofan Mo. "Experimental research on quantum cryptography." a thesis submitted to University of Science and Technology of China for the degree of Doctor of Philosophy in Physics, 2006.
- [5] Wei Chen. "Experimental research on fiber quantum key distribution." a dissertation for doctor's degree, 2008.
- [6] Niu, Jia-Ning, et al. "Optimized channel allocation scheme for jointly reducing four-wave mixing and Raman scattering in the DWDM-QKD system." *Applied optics* 57.27 (2018): 7987-7996.
- [7] Kawahara, H., A. Medhipour, and K. Inoue. "Effect of spontaneous Raman scattering on quantum channel wavelength-multiplexed with classical channel." *Optics communications* 284.2 (2011): 691-696.
- [8] Geng, Jia-Qi, et al. "Coexistence of quantum key distribution and optical transport network based on standard single-mode fiber at high launch power." *Optics Letters* 46.11 (2021): 2573-2576.
- [9] Lin, Rui, and Jiajia Chen. "Minimizing spontaneous Raman scattering noise for quantum key distribution in WDM networks." 2021 Optical Fiber Communications Conference and Exhibition (OFC). IEEE, 2021.
- [10] Qiming Yang. "Research on dispersion compensation and suppression of four-wave mixing effect in WDM optical transmission systems." dissertation submitted to Zhejiang University of Technology for the degree of master, 2009.
- [11] Qiming Yang. "Research on dispersion compensation and suppression of four-wave mixing effect in WDM optical transmission systems." dissertation submitted to Zhejiang University of Technology for the degree of master, 2009.
- [12] Qiming Yang. "Research on dispersion compensation and suppression of four-wave mixing effect in WDM optical transmission systems." dissertation submitted to Zhejiang University of Technology for the degree of master, 2009.